



Model BB1275H

75AH 12V
LiFePO₄ Deep Cycle Battery
Data sheet

Electrical Specification

Voltage	12V
Capacity	75AH
Operating Temperature	-4°F to 135°F (-20°C to 57.2°C)
Efficiency	99%
Self Discharge	2-3% per month
Maximum Series Voltage	48V
Cycles	3K-5K
Built-in BMS	Internal
Resistance	10 mΩ
Usable DoD	100%

Discharging Specification

Max Discharge Current	100A
Peak Discharge Current	200A for 30 Seconds
Surge for Loads over 500A	.5 Seconds
Recommended LVD	10.5V
BMS Discharge Voltage Cut-Off	10V
Reconnect Voltage	10V
Short Circuit Protection	Yes

Recognized Specification

Certifications	UL/CSA-62133-2
Shipping Class	UN3480, Class 9

Drawing Specification

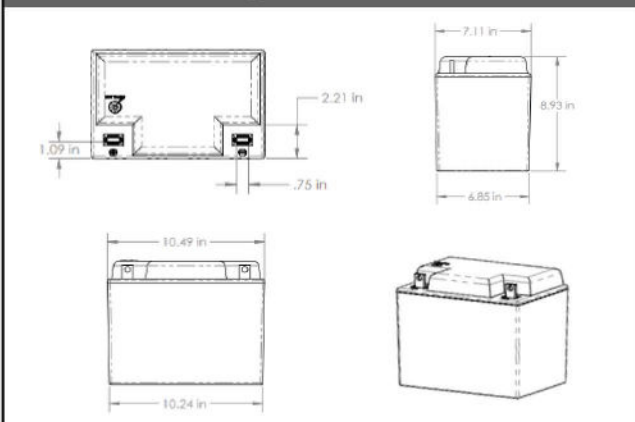

Charging Specification

Recommended Charge Current	.5c
Max Charge Current	37.5A
Absorption Voltage	14.2V-14.6V
Float Voltage	13.4V-13.8V
Equalization Voltage (if applicable)	14.4V
Absorption Time	23 Minutes per 75AH battery bank
BMS Charge Current Cut-Off	.5C Recommended
Recharge/Rebulk Voltage	13.3V
BMS Cell Balancing Voltage Range	14.2V-14.6V
High BMS Voltage Protection	14.7VDC
Temperature Compensation	No/Disable

Mechanical Specification

Dimensions	10.49"L X 7.11"W X 8.93"H
Weight	27 lbs.
Terminal Type	.25" Brass
Terminal Hole	3/8" hole and 3/8" or 5/16" hardware is suggested
Terminal Torque	9-11 Ft-lb.
Case Material	ABS Fire Rated
Cell Type - Electrolyte	LiFePO ₄
Sealed and Water Resistant Case	Non-Submersible
Heat	Proprietary Internal Heating Solution
Heat Enable Terminal	Female M4 Terminal

Temperature Specification

Discharge Temperature	-4°F to 135°F (-20°C to 57.2°C)
Charge Temperature	25°F - 135°F
Storage Temperature	-10°F to 140°F (-23°C to 60°C)
BMS High Temperature Cut-Off	>135°F
BMS Reconnect Temperature	<135°F



Model BB1275H

75AH 12V
LiFePO₄ Deep Cycle Battery
Data sheet

Performed Operation Data

.5C Discharge with Temperature Variations

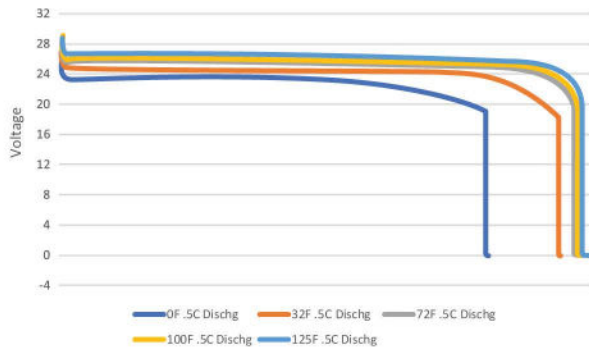

1C Discharge Voltage with Temperature Variations

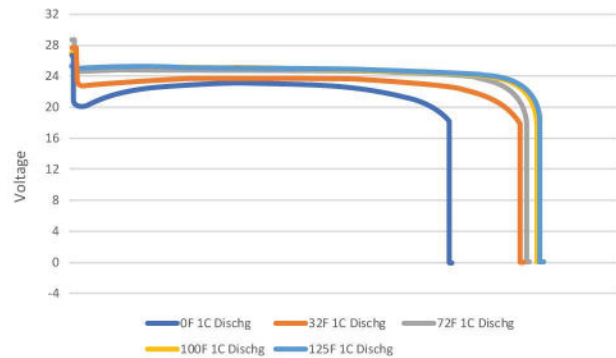

.5C State of Charge with Temperature Variations

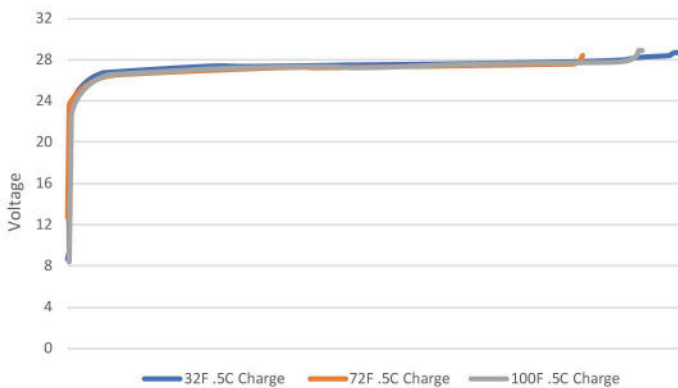

Standard Charge Curve with 3 Stage Charger

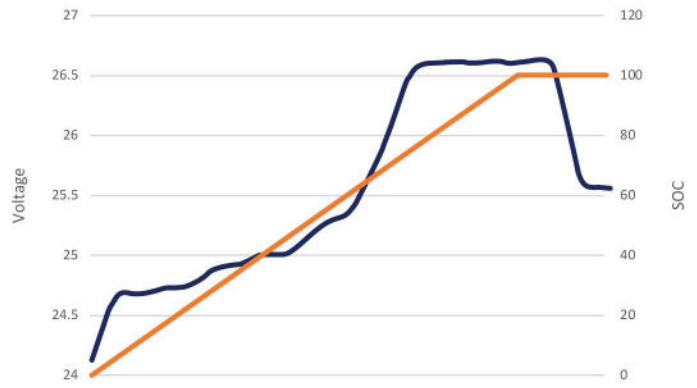

5024H Heater Draw Expected in a 24Hr Period

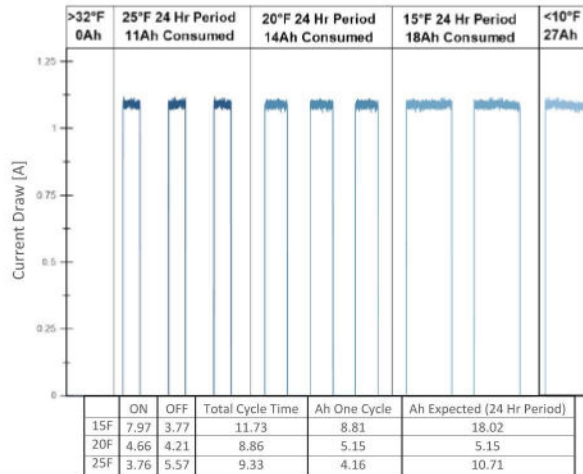
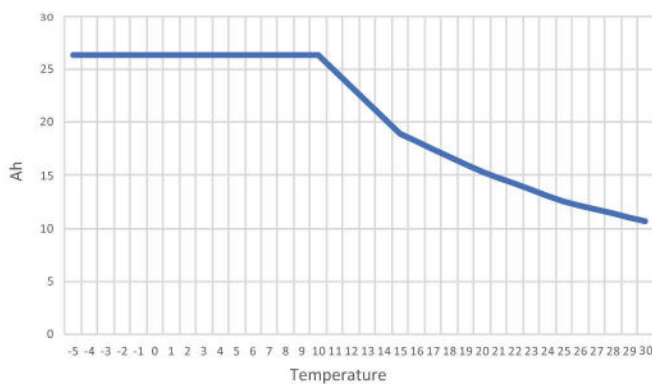

*Note: The storage temperature range is -10°F to 140°F (-23°C to 60°C). We recommend bringing the Battle Born Batteries to a 100% charge and then disconnecting them completely for storage. After six months in storage, your batteries will remain 75 - 80% charged.

Storing batteries in subzero weather (-15°F or more) has the potential to crack the ABS plastic and more importantly could cause a faster loss of capacity, in some cases drastically more than the typical 2 - 4% per month loss.