

What does the EasyStart™ Breeze Soft Starter Do?

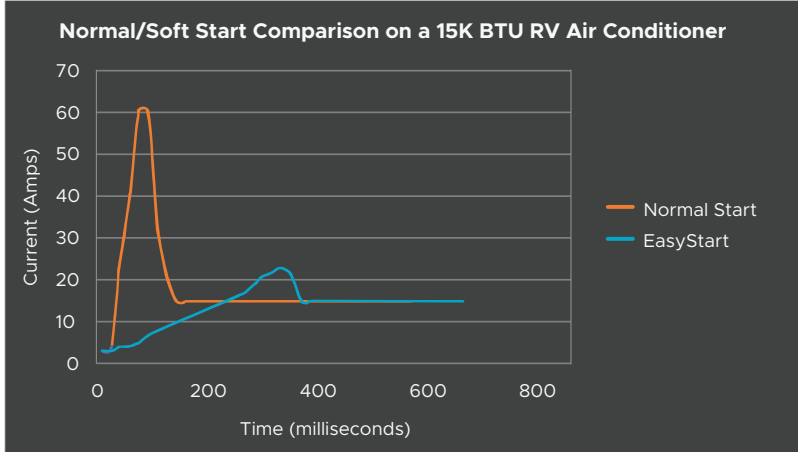

The Hard Spike vs. The Soft Start Ramp Up

Do you notice that "bang" when your AC compressor spikes on? Say goodbye to the bumps in the night with our smoother self-optimizing ramp up sequence. Delivers up to 75% reduced startup current.



Additional Advantages

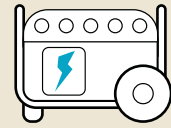

Start your AC without a larger or second generator



"Learns" the compressor motor during the first five startups

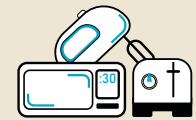

Start your AC while using more appliances

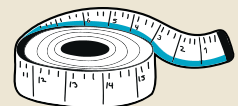

EasyStart™ is properly sized to match the BTUs of each AC unit

Installing the EasyStart™ Breeze

EasyStart's enclosure allows you to mount it anywhere. Wiring is very straightforward—only 4 wires!

The diagram below is an **example** of wiring the EasyStart™. For complete wiring instructions, visit the EasyStart™ Knowledge Bank on microair.net.

Before Installing EasyStart™

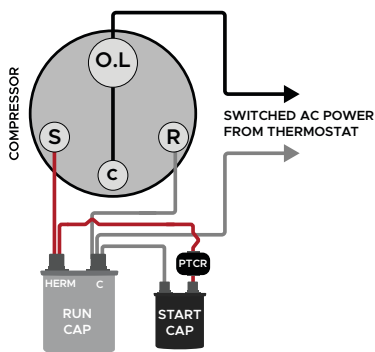

After Installing EasyStart™

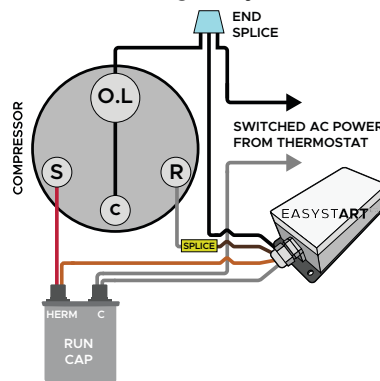

200 First Responders Way, Suite 204, Hamilton NJ 08691
609-259-2636 | micro-air.com

What is the EasyStart™ Breeze Soft Starter?



What is the EasyStart™ Breeze?

EasyStart™ is a one-of-a-kind, UL listed advanced soft starter for single-phase motors operating at 100-120VAC, 50Hz or 60Hz.

The EasyStart™ includes a fully weatherproof plastic enclosure with an integrated mounting flange and a 40" wiring harness.

Micro-Air designs, engineers, and manufactures this soft starter in the USA.



The EasyStart™ Breeze Protects Your Air Conditioner

EasyStart™ monitors and protects the compressor even after the start-up sequence is completed. These fault conditions, which are not monitored in other soft starters, include:

- **Stall** – If the compressor stops rotating during or after the startup sequence is completed.
- **Over Current & Low Current** – If the compressor draws more or less current than what the EasyStart™ is rated for.
- **Open Overload** – If the compressor overload protector opens due to overheating or excessive current draw.
- **Wiring** – The wiring is incorrect or disconnected.
- **Power Interruption** – If a short power interruption occurs, which is typically enough to stall the compressor.
- **Short-Cycle Prevention** – If the thermostat calls to run again before three minutes has elapsed. EasyStart™ only runs the compressor after three minutes have expired.

How EasyStart™ Helps



Sleep without the slam of a loud start

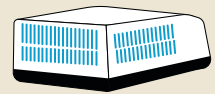

EasyStart™ reduces startup current up to 75%

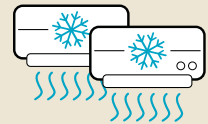

Run 2 RV ACs on a 30 Amp cord*



Its "smart" timer tracks time between compressor cycles, even without power

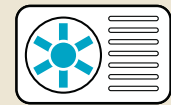

Start your AC for either comfort or necessity

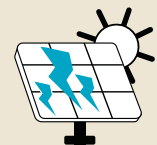

Great for off-grid power like solar arrays



200 First Responders Way, Suite 204, Hamilton NJ 08691
609-259-2636 | micro-air.com

*results depend on overall power requirements